





MODELO AUT. MAJ25



MODELO AUT. MAJ26X



MODELO SS MAJ25



MODELO AUT. SS MAJ45



MODELO AUT. SS MAJ50X



MODELO  
AUT. MAJ80X

MODELOS	AUT. MAJ25	AUT. MAJ26X	AUT. SS MAJ25	AUT. SS MAJ45	AUT. SS MAJ50X	AUT. SS MAJ80X
REFª COMERCIAL	M09359980	M09360000	M09300031	M09300032	M09360020	M09360040
POTÊNCIA	200 W	120 W	200 W	200 W	120 W	370 W
VOLTAGEM	230V/1N/50	230V/1N/50	230V/1N/50	230V/1N/50	230V/1N/50	230V/1N/50
CAPACIDADE	18-25 un./minuto	20-25 un./minuto	20-25 un./minuto	20-25 un./minuto	20-25 un./minuto	40-45 un./minuto
CAPACIDADE DE CARGA	8 Kg	8 Kg	8 Kg	20 Kg	20 Kg	40 Kg
Ø LARANJAS	60-80 mm	40-90 mm	60-80 mm	60-80 mm	40-90 mm	40-90 mm
ALTURA MÁXIMA DA GARRAFA/COPO	16 cm	16 cm	15 cm	28 cm	17 cm	35 cm
DIMENSÕES (LxPxA) mm	450x360x775	400x300x780	450x360x850	450x500x1090	400x450x1080	660x640x1770
PESO	41 Kg	45 Kg	44 Kg	54 Kg	62 Kg	110 Kg
PREÇO SEM IVA	1.693,00 €	1.995,00 €	2.012,00 €	3.039,00 €	3.568,00 €	7.443,00 €

ESPRESSORES DE CITRINOS / CENTRIFUGADORES



MODELO CJ32LH



MODELO CJ32LH XL



MODELO CJ32LH XL AUTOM.



MODELO ETACID1

ESPRESSORES DE CITRINOS

MODELOS	CJ32LH	CJ32LH XL	CJ32LH XL AUTOM.	ETACID1
REFª COMERCIAL	M09300027	M09300028	M09300029	ET1776
POTÊNCIA	180 W	180 W	230 W	570 W
VOLTAGEM	230V/1N/50	230V/1N/50	230V/1N/50	230V/1N/50
DIMENSÕES (LxPxA) mm	220x310x360	210x318x412	210x336x475	180x280x360
PESO	5 Kg	5,5 Kg	8 Kg	10 Kg
PREÇO SEM IVA	<b>343,00 €</b>	<b>405,00 €</b>	<b>588,00 €</b>	<b>702,00 €</b>

CENTRIFUGADORES

MODELOS	EAPC700	EAPB009 (espressor lento)
REFª COMERCIAL	-----	-----
POTÊNCIA	850 W	0,4 Kw
VOLTAGEM	230V/1N/50	230V/1N/50
VELOCIDADE	2800 r.p.m.	37 r.p.m.
DIMENSÕES (LxPxA) mm	230x310x395	250x160x450
PESO	5 Kg	9 Kg
PREÇO SEM IVA	<b>417,00 €</b>	<b>784,00 €</b>



MODELO EAPC700



MODELO EAPB009



MODELO BPOWER XL



MODELO BMASTER ULT.

IDEAIS PARA  
TRABALHAR COM GELO  
JÁ PICADO!



VER PÁG. DOS TRITURADORES

MODELOS	BPOWER XL	BMASTER ULT.
REFª COMERCIAL	M08803000	M09379000
POTÊNCIA	1800 W	1500 W
VOLTAGEM	230V/1N/50	230V/1N/50
CAPACIDADE	2,5 litros	1,5 litros
VELOCIDADE	até 28.000 r.p.m.	20.000 r.p.m.
DIMENSÕES (LxPxA) mm	253x260x566	220x220x445
PESO	5,5 Kg	5 Kg
PREÇO SEM IVA	<b>396,00 €</b>	<b>452,00 €</b>





MODELO ABP1



MODELO ABS1



MODELO ABSG1



MODELO ABP2



MODELO ABS2



MODELO ABSG2

MODELOS	ABP1	ABS1	ABSG1	ABP2	ABS2	ABSG2
POTÊNCIA	600 W	600 W	600 W	600 W + 600 W	600 W + 600 W	600 W + 600 W
VOLTAGEM	230V/1N/50	230V/1N/50	230V/1N/50	230V/1N/50	230V/1N/50	230V/1N/50
CAPACIDADE	1,5 litros	1,5 litros	3,0 litros	1,5 + 1,5 litros	1,5 + 1,5 litros	3,0 + 3,0 litros
VELOCIDADE	13.000 - 16.000 r.p.m.	13.000 - 16.000 r.p.m.	13.000 - 16.000 r.p.m.	13.000 - 16.000 r.p.m.	13.000 - 16.000 r.p.m.	13.000 - 16.000 r.p.m.
DIMENSÕES (LxPxA) mm	175x230x460	175x230x460	175x230x460	175x310x460	175x310x460	175x310x460
PESO	4,5 Kg	4,5 Kg	4,8 Kg	7,5 Kg	7,5 Kg	8,0 Kg
PREÇO SEM IVA	<b>758,00 €</b>	<b>874,00 €</b>	<b>920,00 €</b>	<b>1.173,00 €</b>	<b>1.474,00 €</b>	<b>1.543,00 €</b>



MODELO PBB340E



MODELO PTBB160E



MODELO PMX1000XTXEE



MODELO PMX1200XTXEE



MODELO PMX1100XTXSEE



MODELO PMX1500XTXSEE



MODELOS	PBB340E	PTBB160E	PMX1000 XTXEE	PMX1200 XTXEE	PMX1100 XTXSEE	PMX1500 XTXSEE
POTÊNCIA	1 HP / 750 W	2 HP / 1400 W	3,5 HP / 2600 W	3,5 HP / 2600 W	3,5 HP / 2600 W	3,5 HP / 2600 W
VOLTAGEM	230V/1N/50	230V/1N/50	230V/1N/50	230V/1N/50	230V/1N/50	230V/1N/50
CAPACIDADE	1,4 litros	1,4 litros	2 litros	2 litros	2 litros	2 litros
QUANTIDADE DE BEBIDAS / DIA	25/49	50/74	+ 75	+ 75	+ 75	+ 75
VELOCIDADE	21.700 r.p.m.	24.500 r.p.m.	30.000 r.p.m.	20.000 r.p.m.	45.000 r.p.m.	45.000 r.p.m.
DIMENSÕES (LxPxA) mm	211x191x401	200x190x450	210x211x451	240x240x450	270x240x540	270x240x540
PESO	3,75 Kg	4,53 Kg	6,25 Kg	6,9 Kg	8,9 Kg	8,4 Kg
PREÇO SEM IVA	<b>1.109,00 €</b>	<b>1.421,00 €</b>	<b>1.862,00 €</b>	<b>2.216,00 €</b>	<b>2.299,00 €</b>	<b>2.832,00 €</b>

NOTA : IDEAIS PARA USAR COM GELO EM CUBO (tritaram o gelo em segundos).

# DISPENSADORES DE SUMOS



MODELO MDP1-8



MODELO MDP2-8



MODELO MDP3-8



MODELO DP1-18



MODELO DP2-18



MODELO DP3-18

## MODELOS EQUIPADOS COM TUBOS PARA COLOCAÇÃO DE GELO

## MODELOS EQUIPADOS COM REGULADOR AUTOMÁTICO DE TEMPERATURA

MODELOS	MDP1-8	MDP2-8	MDP3-8	DP1-18	DP2-18	DP3-18
REFª COMERCIAL	M09300541	M09300542	M09300543	M09300530	M09300535	M09300540
POTÊNCIA	-----	-----	-----	151 W	244 W	278 W
VOLTAGEM	-----	-----	-----	230V/1N/50	230V/1N/50	230V/1N/50
CAPACIDADE	1x8 litros	2x8 litros	3x8 litros	1x18 litros	2x18 litros	3x18 litros
TERMOSTATO	-----	-----	-----	7°C/12°C	7°C/12°C	7°C/12°C
DIMENSÕES (LxPxA) mm	260x360x560	550x360x560	860x360x560	340x450x700	490x450x700	730x450x700
PESO	2,8 Kg	5,6 Kg	8,4 Kg	25 Kg	32 Kg	40 Kg
PREÇO SEM IVA	<b>320,00 €</b>	<b>476,00 €</b>	<b>635,00 €</b>	<b>831,00 €</b>	<b>1.048,00 €</b>	<b>1.287,00 €</b>



MODELO C70650025



MODELO C70650020



MODELO C70650015



MODELO C70650030

MODELOS	C70650025	C70650020	C70650015	C70650030
POTÊNCIA	500 W	350 W	500 W	750 W
VOLTAGEM	230V/1N/50	230V/1N/50	230V/1N/50	230V/1N/50
CAPACIDADE	20 litros	10 litros	22 litros	2x 20 litros
TEMPERATURA	+5°C/+10°C	+3°C/+10°C	+3°C/+10°C	+5°C/+10°C
DIMENSÕES (LxPxA) mm	185x520x665	250x390x700	350x405x752	365x520x665
PESO	22 Kg	18 Kg	22 Kg	35 Kg
PREÇO SEM IVA	<b>1.145,00 €</b>	<b>1.213,00 €</b>	<b>1.612,00 €</b>	<b>1.578,00 €</b>



MODELO FIGP2SF



MODELO FIGP2FR



MODELO FIGP3SFF



MODELO  
ATSB



MODELO  
ATSBM

MODELOS	FIGP2SF	FIGP2FR	FIGP3SFF	ATSB	ATSBM
POTÊNCIA	0,15 Kw + 0,35 Kw	0,15 Kw + 0,35 Kw	0,15 Kw + 0,35 Kw + 0,12 Kw	900 W	1050 W
VOLTAGEM	230V/1N/50	230V/1N/50	230V/1N/50	230V/1N/50	230V/1N/50
VELOCIDADE	500-16.000 r.p.m.	800-16.000 r.p.m.	500+16.000+16.000 r.p.m.	1400+1400+16.000 r.p.m.	1400+1400+16.000+15.000 r.p.m.
FUNÇÕES	espremedor de citrinos + blender	blender + triturador de gelo	copo misturador + espremedor de citrinos + blender	blender + triturador de gelo + espremedor de citrinos	blender + triturador de gelo + espremedor de citrinos + copo batedor
DIMENSÕES (LxPxA) mm	380x240x490	380x300x490	510x240x500	480x180x530	480x345x530
PESO	9 Kg	9 Kg	11 Kg	17,5 Kg	20 Kg
PREÇO SEM IVA	<b>1.444,00 €</b>	<b>1.520,00 €</b>	<b>1.643,00 €</b>	<b>2.859,00 €</b>	<b>3.519,00 €</b>



**MILKSHAKERS**

MODELOS	SINGLE	DUPLO
REFª COMERCIAL	M09362101	M09362102
POTÊNCIA	400 W	800 W
VOLTAGEM	230V/1N/50	230V/1N/50
CAPACIDADE DO COPO	1 litro	2x 1 litro
VELOCIDADE	10.000 e 15.000 r.p.m.	10.000 e 15.000 r.p.m.
DIMENSÕES (LxPxA) mm	200x230x500	330x190x480
PESO	3,6 Kg	7,9 Kg
PREÇO SEM IVA	<b>384,00 €</b>	<b>610,00 €</b>



MODELO SINGLE



MODELO DUPLO

IDEIAS PARA GRANIZADOS, FRAPÉS, SLUSHIES E COCKTAILS

**PICADOR / TRITURADORES DE GELO**



MODELO IRPH-65



MODELO FIROGM



MODELO FITRL

MODELOS	IRPH-65	FIROGM	FITRL
REFª COMERCIAL	IR7616300	-----	-----
POTÊNCIA	250 W	0,15 Kw	0,35 Kw
VOLTAGEM	230V/1N/50	230V/1N/50	230V/1N/50
PRODUÇÃO	-----	120 kg/hora	120 kg/hora
VELOCIDADE	-----	800 r.p.m.	1200 r.p.m.
DIMENSÕES (LxPxA) mm	400x200x305	210x300x500	210x465x310
PESO	5 Kg	5 Kg	8 Kg
PREÇO SEM IVA	<b>340,00 €</b>	<b>1.003,00 €</b>	<b>1.358,00 €</b>

MODELO	C70650005
POTÊNCIA	0,93 Kw
VOLTAGEM	230V/1N/50
CAPACIDADE	2x 12 litros
CÔR	aço inoxidável
DIMENSÕES (LxPxA) mm	390x530x780
PESO	48 Kg
PREÇO SEM IVA	<b>2.903,00 €</b>



MODELO	C70650010
POTÊNCIA	1,28 Kw
VOLTAGEM	230V/1N/50
CAPACIDADE	3x 12 litros
CÔR	aço inoxidável
DIMENSÕES (LxPxA) mm	590x530x780
PESO	48 Kg
PREÇO SEM IVA	<b>3.836,00 €</b>



**TERMOS**



MODELOS  
STER5L E STER10L

MODELO STER5+5L

MODELOS	STER5L	STER10L	STER5+5L
POTÊNCIA	1,2 Kw	1,8 Kw	2x 1,2 Kw = 2,4 Kw
VOLTAGEM	230V/1N/50	230V/1N/50	230V/1N/50
CAPACIDADE	-----	-----	-----
TEMPERATURA	-----	-----	-----
DIMENSÕES (LxPxA) mm	280x310x520	320x350x615	540x310x520
PESO	8 Kg	12 Kg	16 Kg
PREÇO SEM IVA	<b>938,00 €</b>	<b>1.069,00 €</b>	<b>1.466,00 €</b>

**ARREFECEDORES**



MODELO	BKV6L
REFª COMERCIAL	B190076
POTÊNCIA	0,061 Kw
VOLTAGEM	230V/1N/50
CAPACIDADE	6 litros / 3 pacotes 1 litro
TEMPERATURA	0°C/4°C
TEMPERATURA AMBIENTE	25°C
DIMENSÕES (LxPxA) mm	interiores 160x125x280 exteriores 225x460x452
PESO	12,9 Kg
PREÇO SEM IVA	<b>1.225,00 €</b>



**AQUECEDORES**



**PRODUTOS  
NOVOS**

MODELO XDAL 2P

MODELOS	XDAL 2P	XDAL 3P	XDAL 6P
POTÊNCIA	650 W	1050 W	2100 W
VOLTAGEM	230V/1N/50	230V/1N/50	230V/1N/50
CAPACIDADE	2 pacotes leite	3 pacotes leite	6 pacotes leite
DIMENSÕES (LxPxA) mm	195x145x250	275x145x250	290x275x250
PESO	5,8 Kg	7,7 Kg	15,7 Kg
PREÇO SEM IVA	<b>498,00 €</b>	<b>541,00 €</b>	<b>1.020,00 €</b>



MODELO XDAL 3P



MODELO XDAL 6P



MODELO	SC01
POTÊNCIA	1200 W
VOLTAGEM	230V/1N/50
CAPACIDADE	3 litros
TEMPERATURA	0°C/90°C
DIMENSÕES (LxPxA) mm	210x210x380
PESO	5 Kg
PREÇO SEM IVA	<b>646,00 €</b>



MODELOS	ETCHOC05L	ETCHOC010L
REFª COMERCIAL	ET1753	ET1754
POTÊNCIA	1000 W	1000 W
VOLTAGEM	230V/1N/50	230V/1N/50
CAPACIDADE	5 litros	10 litros
TEMPERATURA	90°C	90°C
DIMENSÕES (LxPxA) mm	280x410x460	280x410x580
PESO	6,8 Kg	7 Kg
PREÇO SEM IVA	<b>998,00 €</b>	<b>1.047,00 €</b>



## CONGELADORES DE COPOS



MODELO	M09403000
DIMENSÕES (LxPxA) mm	130x270x410
PESO	2,8 Kg
PREÇO SEM IVA	<b>702,00 €</b>

NOTA : DEVE LIGAR-SE A BOTIJA DE DIÓXIDO DE CARBONO LIQUÍDO.



MODELO IESC50



MODELO IESC50CR

MODELOS	IESC50	IESC50CR
POTÊNCIA	375 W	390 W
POTÊNCIA FRIGORÍFICA (TRA -30°C)	445 W	445 W
VOLTAGEM	230V/1N/50	230V/1N/50
CAPACIDADE	95 litros	95 litros
TEMPERATURA	-5°C/-18°C	-5°C/-10°C
CLASSE CLIMÁTICA	4/38°C	4/38°C
REFRIGERANTE	R290	R290
CARACTERÍSTICAS	1 porta / 2 guias	1 porta / 2 guias
DIMENSÕES (LxPxA) mm	570x600x850	570x600x850
PREÇO SEM IVA	<b>2.133,00 €</b>	<b>2.316,00 €</b>

## MÁQUINA DE GELO SECO



MODELO	M09403100
POTÊNCIA	10 W
VOLTAGEM	230V/1N/50
PRODUÇÃO	185 gr. / 120 segundos
DIMENSÕES DO CILINDRO	56 x 112 mm
DIMENSÕES (LxPxA) mm	198x198x224
PESO	5 Kg
PREÇO SEM IVA	<b>1.395,00 €</b>

NOTA : DEVE LIGAR-SE A BOTIJA DE DIÓXIDO DE CARBONO LIQUÍDO.



O GELO SECO FORNECE  
UMA NÉVOA ESPECTACULAR  
PARA DECORAÇÃO  
DE PRATOS E COCKTAILS



MODELO CREPE SINGLE



MODELO CREPE DOUBLE



MODELO FICR400G1



MODELO FICR400G2



**GÁS**

MODELOS	CREPE SINGLE	CREPE DOUBLE	FICR400G1	FICR400G2
REFª COMERCIAL	M09374070	M09374071	-----	-----
POTÊNCIA	3000 W	2x 3000 W	3600 W	3600 W + 3600 W
VOLTAGEM	230V/1N/50	230V/1N/50	-----	-----
PRATO / DIÂMETRO	1 prato / Ø 400 mm	2 pratos / Ø 400 mm cada	1 prato / Ø 400 mm	2 pratos / Ø 400 mm cada
TEMPERATURA	0°C/300°C	0°C/300°C	50°C/280°C	50°C/280°C
DIMENSÕES (LxPxA) mm	450x485x240	860x500x250	480x480x270	900x480x270
PESO	15 Kg	30 Kg	23 Kg	46 Kg
PREÇO SEM IVA	<b>438,00 €</b>	<b>708,00 €</b>	<b>1.507,00 €</b>	<b>2.555,00 €</b>



MODELO BUBBLE



MODELO LOLLY

MODELOS	BUBBLE	LOLLY
REFª COMERCIAL	M09374210	M09374251
POTÊNCIA	1415 W	1750 W
VOLTAGEM	230V/1N/50	230V/1N/50
TEMPERATURA	50°C/230°C	50°C/300°C
TAMANHO DO WAFFLE (LxPxA) mm	180x200x24	210x380x260
DIMENSÕES (LxPxA) mm	225x315x270	300x380x260
PESO	7 Kg	13 Kg
PREÇO SEM IVA	<b>703,00 €</b>	<b>703,00 €</b>



MODELO HEARTS SINGLE



MODELO HEARTS DOUBLE

	HEARTS	
MODELOS	SINGLE	DOUBLE
REFª COMERCIAL	M09365100	M09365101
POTÊNCIA	1000 W	2x 1000 W
VOLTAGEM	230V/1N/50	230V/1N/50
TEMPERATURA	50°C/300°C	50°C/300°C
DIMENSÕES (LxPxA) mm	255x380x270	520x380x270
PESO	5,5 Kg	11 Kg
PREÇO SEM IVA	<b>410,00 €</b>	<b>594,00 €</b>



MODELO 3x3



MODELO SINGLE



MODELO DOUBLE

	CLASSIC		
MODELOS	3x3	SINGLE	DOUBLE
REFª COMERCIAL	M09374201	M09365105	M09365106
POTÊNCIA	1750 W	1600 W	2x 1600 W
VOLTAGEM	230V/1N/50	230V/1N/50	230V/1N/50
TAMANHO DO WAFFLE (LxPxA) mm	99x160	100x164x25	100x164
TEMPERATURA	50°C/300°C	50°C/300°C	50°C/300°C
DIMENSÕES (LxPxA) mm	380x300x265	300x380x270	630x380x270
PESO	11 Kg	10 Kg	18 Kg
PREÇO SEM IVA	<b>578,00 €</b>	<b>708,00 €</b>	<b>886,00 €</b>



MODELO MINI DONUT 6



MODELO MINI DONUT 12



MODELO MINI DONUT 15



MODELO AUTOMATIC DONUT



MODELOS	MINI DONUT 6	MINI DONUT 12	MINI DONUT 15	AUTOMATIC DONUT
REFª COMERCIAL	M09374010	M09374011	M09374012	M09374000
POTÊNCIA	1650 W	1650 W	1650 W	3000 W
VOLTAGEM	230V/1N/50	230V/1N/50	230V/1N/50	230V/1N/50
TAMANHO DOS DONUTS	Ø 80-30 mm	Ø 50-20 mm	Ø 45-20 mm	3-5 cm / 5-7 cm / 7-10 cm
PRODUÇÃO	6 donuts de cada vez	12 donuts de cada vez	15 donuts de cada vez	500 unidades/hora
TEMPERATURA	50°C/300°C	50°C/300°C	50°C/300°C	60°C/240°C
DIMENSÕES (LxPxA) mm	380x310x270	380x310x270	380x310x270	965x330x650
PESO	11 Kg	11 Kg	11 Kg	35 Kg
PREÇO SEM IVA	<b>511,00 €</b>	<b>511,00 €</b>	<b>511,00 €</b>	<b>2.525,00 €</b>



**PRODUTOS  
NOVOS**



MODELO PANCAKE PLATE 9



MODELO PANCAKE 1



MODELO PANCAKE 9



MODELO PANCAKE 4



MODELOS	PANCAKE PLATE 9	PANCAKE 1	PANCAKE 9	PANCAKE 4
REFª COMERCIAL	M09374125	M09374120	M09374122	M09374121
POTÊNCIA	850 W	1650 W	1650 W	1650 W
VOLTAGEM	230V/1N/50	230V/1N/50	230V/1N/50	230V/1N/50
TAMANHO DAS PANQUECAS	Ø 80 mm	Ø 215 x 10 mm	Ø 75 x 16 mm	Ø 100 mm
PRODUÇÃO	9 panquecas de cada vez	1 panqueca de cada vez	9 panquecas de cada vez	4 panquecas de cada vez
TEMPERATURA	50°C/300°C	50°C/300°C	50°C/300°C	50°C/300°C
DIMENSÕES (LxPxA) mm	300x380x200	300x380x260	300x380x260	300x400x290
PESO	5,5 Kg	12 Kg	12 Kg	12 Kg
PREÇO SEM IVA	<b>479,00 €</b>	<b>578,00 €</b>	<b>578,00 €</b>	<b>613,00 €</b>

**PRODUTOS  
NOVOS**



MODELO PROFITEROLE25



MODELO PROFITEROLE100

MODELOS	PROFITEROLE25	PROFITEROLE100
REFª COMERCIAL	M09374130	M09374132
POTÊNCIA	850 W	1600 W
VOLTAGEM	230V/1N/50	230V/1N/50
TAMANHO DOS PROFITEROLES	Ø 45 x 7 mm	Ø 40 x 7 mm
PRODUÇÃO	25 profiteroles de cada vez	100 profiteroles de cada vez
TEMPERATURA	50°C/300°C	50°C/300°C
DIMENSÕES (LxPxA) mm	300x380x210	540x590x200
PESO	5,5 Kg	18,5 Kg
PREÇO SEM IVA	<b>445,00 €</b>	<b>1.146,00 €</b>



**DISTRIBUIDORES DE MASSA**

MODELOS	DISPENSER 1.3	DISPENSER DELUXE 1.6
REFª COMERCIAL	M09374160	M09374161
QUANTIDADE DE MASSA	1,3 litros	1,6 litros
DIMENSÕES DO BICO	8 mm	3 / 6 / 8 mm
DIMENSÕES (LxPxA) mm	300x380x200	240x245x200
PESO	5,5 Kg	3 Kg
PREÇO SEM IVA	<b>216,00 €</b>	<b>266,00 €</b>



MODELO DISPENSER 1.3



MODELO DISPENSER DELUXE 1.6





MODELO NERVURADA SINGLE  
MODELO NERVURADA PANINI



MODELO SANDWICH PANINI



MODELO NERVURADA DOUBLE  
MODELO LISA DOUBLE

MODELOS	NERVURADA SINGLE	NERVURADA PANINI	SANDWICH PANINI	NERVURADA DOUBLE	LISA DOUBLE
REFª COMERCIAL	M09300430	M09300436	M09374170	M09300435	M09300437
TEMPERATURA	0°C/300°C	0°C/300°C	50°C/300°C	0°C/300°C	0°C/300°C
POTÊNCIA	1800 W	2200 W	1650 W	2x 1800 W	2x 1800 W
VOLTAGEM	230V/1N/50	230V/1N/50	230V/1N/50	230V/1N/50	230V/1N/50
PLACA SUPERIOR (LxP)	214x214 mm	335x220 mm	120x140x20 mm	214x214 mm	214x214 mm
PLACA INFERIOR (LxP)	220x235 mm	335x220 mm		220x235 mm	220x235 mm
DIMENSÕES (LxPxA) mm	290x305x210	410x305x210	380x310x270	570x305x210	570x305x210
PESO	17,5 Kg	20 Kg	10 Kg	24 Kg	24 Kg
PREÇO SEM IVA	<b>426,00 €</b>	<b>468,00 €</b>	<b>514,00 €</b>	<b>702,00 €</b>	<b>763,00 €</b>



MODELO FIPV27LL  
MODELO FIPV27LR



MODELO FIPV40LL  
MODELO FIPV40LR



MODELO FIPV55LL  
MODELO FIPV55LR

**VITROCERÂMICOS**

MODELOS	FIPV27LL	FIPV27LR	FIPV40LL	FIPV40LR	FIPV55LL	FIPV55LR
POTÊNCIA	1700 W	1700 W	2000 W	2000 W	3400 W	3400 W
VOLTAGEM	230V/1N/50	230V/1N/50	230V/1N/50	230V/1N/50	230V/1N/50-400V/3N/50	230V/1N/50-400V/3N/50
TEMPERATURA	50°C/300°C	50°C/300°C	50°C/300°C	50°C/300°C	50°C/300°C	50°C/300°C
TAMANHO DA PLACA	270x300 mm	270x300 mm	400x300 mm	400x300 mm	550x300 mm	550x300 mm
DIMENSÕES (LxPxA) mm	340x450x190/600	340x450x190/600	490x450x190/600	490x450x190/600	630x450x190/600	630x450x190/600
PESO	11,5 Kg	11,5 Kg	15,5 Kg	15,5 Kg	23 Kg	23 Kg
PREÇO SEM IVA	<b>1.419,00 €</b>	<b>1.606,00 €</b>	<b>1.569,00 €</b>	<b>1.744,00 €</b>	<b>2.170,00 €</b>	<b>2.507,00 €</b>



MODELO XDT 1 2R



MODELO XDT 2 2R



MODELO XDT 2TI 2R



MODELO XDT 1TI 2R



SEM TEMPORIZADOR

COM TEMPORIZADOR

MODELOS	XDT 1 2R	XDT 1TI 2R	XDT 2 2R	XDT 2TI 2R
POTÊNCIA	2000 W	2000 W	3000 W	3000 W
VOLTAGEM	230V/1N/50	230V/1N/50	230V/1N/50	230V/1N/50
CAPACIDADE	6 torradas	6 torradas	2x 6 torradas	2x 6 torradas
DIMENSÕES (LxPxA) mm	532x270x280	532x270x280	532x270x370	532x270x370
PESO	7,6 Kg	7,6 Kg	9,3 Kg	9,4 Kg
PREÇO SEM IVA	<b>292,00 €</b>	<b>307,00 €</b>	<b>344,00 €</b>	<b>359,00 €</b>



MODELO MTT-150  
MODELO MTT-300  
MODELO MTT-450



MODELO ITTH3000



MODELO ITTV2400



MODELO  
ITTV4000



MODELOS	MTT-150	MTT-300	MTT-450	ITTH3000	ITTV2400	ITTV4000
REFª COMERCIAL	M09300055	M09300056	M09300057	-----	-----	-----
POTÊNCIA	1340 W	2240 W	2640 W	1500 W + 1500 W	1400 W + 1400 W	2000 W + 2000 W
VOLTAGEM	230V/1N/50	230V/1N/50	230V/1N/50	230V/1N/50	230V/1N/50	400V/3N/50
OPERAÇÃO	torrar	torrar	torrar	torrar / gratinar / aquecer	torrar	torrar
Nº DE RESISTÊNCIAS	-----	-----	-----	2	2	2
LARGURA DA FAIXA	180 mm	280 mm	360 mm	200 mm	260 mm	360 mm
ALTURA DA ENTRADA	85 mm	85 mm	85 mm	70 mm	70 mm	70 mm
DIMENSÕES (LxPxA) mm	290x420x390	370x420x390	470x420x390	750x420x250	480x510x410	570x620x400
PESO	16 Kg	16 Kg	20,5 Kg	-----	-----	-----
PREÇO SEM IVA	<b>708,00 €</b>	<b>828,00 €</b>	<b>949,00 €</b>	<b>1.955,00 €</b>	<b>1.901,00 €</b>	<b>2.289,00 €</b>



MODELO  
EX-CGSP195E



MODELO EX-CGSP220E  
MODELO EX-CGSP250E



MODELO  
EX-CGSP250RE



MODELOS  
MS220 / MS250 / MS300



MODELOS	EX-CGSP 195E	EX-CGSP 220E	EX-CGSP 250E	MS220	EX-CGSP 250RE	MS250	MS300
REFª COMERCIAL	E19013934	E19013935	E19012275	M09300490	E19013936	M09300495	M09300500
POTÊNCIA	110 W	140 W	140 W	150 W	140 W	150 W	250 W
VOLTAGEM	230V/1N/50	230V/1N/50	230V/1N/50	230V/1N/50	230V/1N/50	230V/1N/50	230V/1N/50
DIÂMETRO DA LÂMINA	195 mm	220 mm	250 mm	220 mm	250 mm	250 mm	300 mm
CAPACIDADE DE CORTE	200x130 mm	230x160 mm	230x180 mm	-----	230x180 mm	-----	-----
ESPESSURA DO CORTE	0-15 mm	0-15 mm	0-15 mm	1-12 mm	0-15 mm	1-12 mm	1-12 mm
CÔR	aço inoxidável	aço inoxidável	aço inoxidável	aço inoxidável	vermelho	aço inoxidável	aço inoxidável
DIMENSÕES (LxPxA) mm	430x300x292	448x363x335	480x363x365	450x280x320	480x363x365	470x280x380	530x330x460
PESO	11 Kg	13 Kg	14 Kg	14,1 Kg	14 Kg	14,3 Kg	24,3 Kg
PREÇO SEM IVA	<b>551,00 €</b>	<b>711,00 €</b>	<b>759,00 €</b>	<b>666,00 €</b>	<b>831,00 €</b>	<b>729,00 €</b>	<b>944,00 €</b>



MODELOS  
EX-CGSP220  
EX-CGSP250  
EX-CGSP275



MODELO  
EX-CGSP250R



MODELO  
EX-CGSP300R



MODELOS  
EX-CGP300  
EX-CGP330  
EX-CGP350



**INTERRUPTOR COM RELÉ**

MODELOS	EX-CGSP 220	EX-CGSP 250	EX-CGSP 250R	EX-CGSP 275	EX-CGSP 300	EX-CGP 300	EX-CGP 330	EX-CGP 350
REFª COMERCIAL	E19000574	E19000575	E19013933	E19000576	E19000577	E19000571	E19000572	E19000573
POTÊNCIA	140 W	185 W	185 W	185 W	260 W	370 W	370 W	370 W
VOLTAGEM	230V/1N/50	230V/1N/50	230V/1N/50	230V/1N/50	230V/1N/50	230V/1N/50	230V/1N/50	230V/1N/50
DIÂMETRO DA LÂMINA	220 mm	250 mm	250 mm	275 mm	300 mm	300 mm	330 mm	350 mm
CAPACIDADE DE CORTE	210x160 mm	220x190 mm	220x190 mm	220x220 mm	260x220 mm	285x230 mm	285x250 mm	325x260 mm
ESPESSURA DO CORTE	0-15 mm	0-16 mm	0-16 mm	0-16 mm	0-16 mm	0-16 mm	0-16 mm	0-16 mm
CÔR	aço inoxidável	aço inoxidável	vermelho	aço inoxidável	aço inoxidável	aço inoxidável	aço inoxidável	aço inoxidável
DIMENSÕES (LxPxA) mm	580x405x340	620x425x370	620x425x370	620x440x390	650x495x440	770x540x465	770x550x465	890x585x480
PESO	14 Kg	16 Kg	16 Kg	19 Kg	24 Kg	30 Kg	32 Kg	36 Kg
PREÇO SEM IVA	<b>944,00 €</b>	<b>1.095,00 €</b>	<b>1.214,00 €</b>	<b>1.251,00 €</b>	<b>1.563,00 €</b>	<b>2.259,00 €</b>	<b>2.509,00 €</b>	<b>2.928,00 €</b>



MODELOS  
ASG220T - ASG250T - ASG275T - ASG300T



MODELO  
EX-CGE300

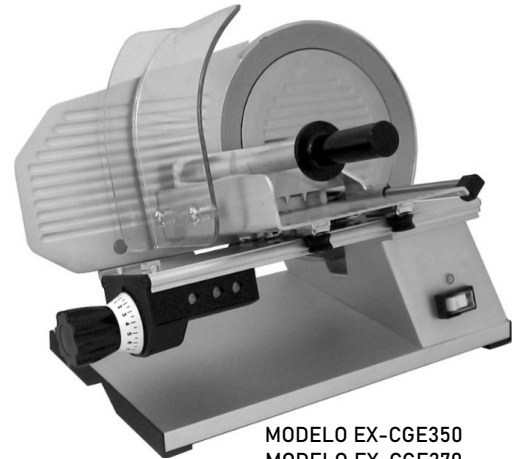

MODELO EX-CGE350  
MODELO EX-CGE370

### DE ENGRENAGEM

MODELOS	ASG220T	ASG250T	ASG275T	ASG300T	EX-CGE300	EX-CGE350	EX-CGE370
REFª COMERCIAL	-----	-----	-----	-----	E19000568	E19000569	E19000570
POTÊNCIA	200 W	200 W	200 W	320 W	250 W	370 W	370 W
VOLTAGEM	230V/1N/50	230V/1N/50	230V/1N/50	230V/1N/50	230V/1N/50	230V/1N/50	230V/1N/50
DIÂMETRO DA LÂMINA	220 mm	250 mm	275 mm	300 mm	300 mm	350 mm	370 mm
CAPACIDADE DE CORTE	195x155	230x175	230x180	265x210	270x220 mm	310x245 mm	310x255 mm
ESPESSURA DO CORTE	0-16 mm	0-16 mm	0-16 mm	0-16 mm	0-15 mm	0-15 mm	0-13 mm
CÔR	aço inoxidável	aço inoxidável	aço inoxidável	aço inoxidável	aço inoxidável	aço inoxidável	aço inoxidável
DIMENSÕES (LxPxA) mm	380x490x370	425x525x380	425x535x405	480x640x515	650x540x455	720x580x470	720x580x480
PESO	12,50 Kg	14 Kg	15 Kg	20,80 Kg	30 Kg	48 Kg	49 Kg
PREÇO SEM IVA	<b>1.312,00 €</b>	<b>1.567,00 €</b>	<b>1.658,00 €</b>	<b>2.469,00 €</b>	<b>3.536,00 €</b>	<b>4.335,00 €</b>	<b>4.507,00 €</b>

### AUTOMÁTICAS

MODELOS	ASG350A	EX-CGE350A
REFª COMERCIAL	-----	E19000508
POTÊNCIA	250 W	520 W
VOLTAGEM	230V/1N/50	230V/1N/50
DIÂMETRO DA LÂMINA	350 mm	350 mm
CAPACIDADE DE CORTE	280x245	320x255 mm
ESPESSURA DO CORTE	0-16 mm	0-15 mm
CÔR	aço inoxidável	aço inoxidável
DIMENSÕES (LxPxA) mm	570x710x630	810x630x560
PESO	48 Kg	70 Kg
PREÇO SEM IVA	<b>5.186,00 €</b>	<b>7.116,00 €</b>



MODELO  
ASG350A



PAINEL DE COMANDO DIGITAL



MODELO  
EX-CGE350A





DISPENSADORES DE CAFÉ



FERVEDORES DE ÁGUA

DISPENSADORES DE CAFÉ

FERVEDORES DE ÁGUA

	DISPENSADORES DE CAFÉ		FERVEDORES DE ÁGUA	
MODELOS	COFFEE 10 L	COFFEE 15 L	WATER 10 L	WATER 20 L
REFª COMERCIAL	M09300598	M09300599	M09300595	M09300596
POTÊNCIA	1520 W	1520 W	2000 W	2500 W
VOLTAGEM	230V/1N/50	230V/1N/50	230V/1N/50	230V/1N/50
CAPACIDADE	80 chávenas	120 chávenas	10 litros	20 litros
TEMPO MÉDIO DE PREPARAÇÃO	10 litros : 45-60 minutos	15 litros : 45-60 minutos	-----	-----
TEMPO MÉDIO DE AQUECIMENTO	-----	-----	20-30 minutos	20-30 minutos
TEMPERATURA	-----	-----	30°C/110°C	30°C/110°C
DIMENSÕES (LxPxA) mm	340x340x480	340x340x590	290x290x405	310x310x523
PESO	4 Kg	5 Kg	2,8 Kg	3,6 Kg
PREÇO SEM IVA	<b>354,00 €</b>	<b>384,00 €</b>	<b>296,00 €</b>	<b>331,00 €</b>

MÁQUINAS AUTOMÁTICAS PARA CAFÉ EXPRESSO / MOÍNHOS DE CAFÉ



MODELO GRUPPO 1



MODELO GRUPPO 2



MODELO GRUPPO 2 / GRANDE



MODELO GRUPPO 3 / GRANDE



MODELOS	GRUPPO 1	GRUPPO 2	GRUPPO 2 / GRANDE	GRUPPO 3 / GRANDE
REFª COMERCIAL	M08804000	M08804050	M08804100	M08804150
POTÊNCIA	2800 W	2800 W	3350 W	6350 W
VOLTAGEM	230V/1N/50	230V/1N/50	230V/1N/50	400V/3N/50
PRODUÇÃO / HORA	240 chávenas / hora	480 chávenas / hora	480 chávenas / hora	720 chávenas / hora
GRUPOS	1	2	2	3
CAPACIDADE DA CALDEIRA	6,0 litros	6,0 litros	11,5 litros	17,5 litros
DIMENSÕES (LxPxA) mm	460x590x530	460x590x530	680x590x530	980x590x530
PESO	35 Kg	45 Kg	54 Kg	71 Kg
PREÇO SEM IVA	<b>3.245,00 €</b>	<b>3.781,00 €</b>	<b>4.323,00 €</b>	<b>5.297,00 €</b>



MODELO ELEGANCE 500



MODELO ELEGANCE 600  
MODELO ELEGANCE 600A



MODELOS	ELEGANCE 500	ELEGANCE 600	ELEGANCE 600A *
REFª COMERCIAL	M08804500	M08804525	M08804550
POTÊNCIA	270 W	356 W	356 W
VOLTAGEM	230V/1N/50	230V/1N/50	230V/1N/50
PRODUÇÃO / MINUTOS	500 gr. / 6 min	500 gr. / 5 min	500 gr. / 5 min
CAPACIDADE DO RECIPIENTE	500 gr.	2 Kg	2 Kg
DIMENSÕES (LxPxA) mm	170x340x410	210x380x600	210x380x600
PESO	6 Kg	9 Kg	9 Kg
PREÇO SEM IVA	<b>608,00 €</b>	<b>735,00 €</b>	<b>769,00 €</b>

\* AUTOMÁTICA



MODELO	BKVIL CLASSIC *
REFª COMERCIAL	B190052
POTÊNCIA	2,7 Kw
VOLTAGEM	230V/1N/50
CAPACIDADE	80 chávenas/dia
CAPACIDADE DE SAÍDA MÁXIMA	40 chávenas de 120 ml/hora
CAPACIDADE DO TANQUE DE ÁGUA	1,8 litros
CAPACIDADE RECIPIENTE RESÍDUOS	aproximadamente 35 chávenas
PROGRAMAÇÃO	6 programas ajustáveis
DIMENSÕES (LxPxA) mm	305x330x580
PESO	17,4 Kg
PREÇO SEM IVA	<b>4.030,00 €</b>

\* ESTA MÁQUINA TEM PEÇAS DE DESGASTE QUE TÊM UMA DURAÇÃO ESTIMADA DE 25.000 OU 50.000 SERVIÇOS.  
(PARA MAIS INFORMAÇÕES É FAVOR NOS CONTACTAR.)



COMPATÍVEL  
COM CÁPSULAS  
NESPRESSO



MODELO CA-FOX-P



MODELO CA-FOX-E



MODELO CA-MYCAPS

MODELOS	CA-FOX-P	CA-FOX-E	CA-MYCAPS
POTÊNCIA	550 W	550 W	550 W (café) / 1050 W (vapor)
VOLTAGEM	230V/1N/50	230V/1N/50	230V/1N/50
POTÊNCIA TOTAL DA BOMBA	48 W	48 W	48 W
PRESSÃO MÁXIMA	20 bar	20 bar	20 bar
CAPACIDADE DO TANQUE	1,20 litros	1,20 litros	2 litros
TAMANHO DA CÁPSULA	Ø 36 mm	nespresso	Ø 36 mm
TEMPERATURA	95°C	95°C	-----
VERSÃO	mecânica	electrónica	electrónica
CORES DISPONÍVEIS	prata	preto	prata / preto / vermelho
DIMENSÕES (LxPxA) mm	170x370x294	170x370x294	185x375x30
PESO	5,05 Kg	5,05 Kg	5 Kg
PREÇO SEM IVA	<b>425,00 €</b>	<b>455,00 €</b>	<b>513,00 €</b>



### CÁPSULAS



MODELO CA-FOX-E



MODELOS  
CA-FOX-P / CA-MYCAPS



MODELO CA-BETA



MODELO CA-D3



MODELO CA-D2



MODELO CA-THETA

MODELOS	CA-BETA *	CA-D3 **	CA-D2	CA-THETA
POTÊNCIA	1100 W	1650 W	1100 W	1100 W
VOLTAGEM	230V/1N/50	230V/1N/50	230V/1N/50	230V/1N/50
GRUPOS	2	3	2	2
POTÊNCIA DA CALDEIRA	1400 W	-----	1400 W	1400 W
POTÊNCIA TOTAL DA BOMBA	48 W	48 W	48 W	48 W
PRESSÃO MÁXIMA	15 bar	20 bar	20 bar	20 bar
CAPACIDADE DO TANQUE	2x 2 litros	2x 2 litros	2x 2 litros	2x 2 litros
TAMANHO DA CÁPSULA	Ø 44 mm	Ø 36 mm	Ø 36 mm	compatíveis NESPRESSO
VERSÃO	electrónica	electrónica	electrónica	electrónica
DIMENSÕES (LxPxA) mm	570x450x370	520x390x380	520x480x380	520x480x380
PESO	24 kilos	23 kilos	23 kilos	23 kilos
PREÇO SEM IVA	<b>1.838,00 €</b>	<b>1.843,00 €</b>	<b>2.008,00 €</b>	<b>2.008,00 €</b>

\* MODELO CA-BETA, UTILIZA CÁPSULA DE PAPEL (mais económicas).

\*\* MODELO CA-D3 TEM MENOS DE METADE DO CONSUMO ELÉCTRICO DE UMA MÁQUINA DE CAFÉ COMUM E NÃO REQUER ESGOTO NEM ENTRADA DE ÁGUA, SENDO APENAS NECESSÁRIO LIGAR A UMA TOMADA.



### CÁPSULAS



MODELO CA-BETA



MODELOS  
CA-D2 / CA-D3



MODELO CA-THETA